

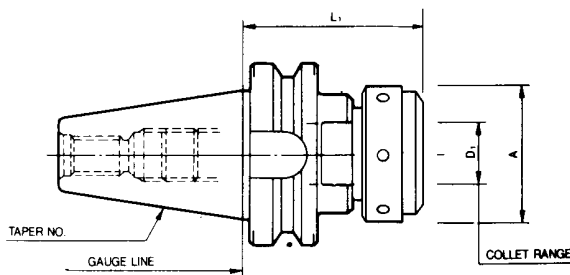

TG Collet Chucks

BT & CT Flange Tools TG Collet Chucks

For use with TG style
collets. See pages 2-1 and
2-2 for collet information



BT

Taper	Order No.	Device Type	D1 (in)	L1 (in)	A (in)
30	473-405	BT30 – TG100 – 101.6	0.063 – 1.000	4.00	2.50
40	473-105	BT40 – TG100 – 100	0.063 – 1.000	3.94	2.50
40	473-106	BT40 – TG100 – 133	0.063 – 1.000	5.25	2.50
40	473-107	BT40 – TG100 – 184	0.063 – 1.000	7.25	2.50
50	473-305*	BT50 – TG100 – 100	0.063 – 1.000	3.94	2.50



* While stock is still available.

**ALL TG
COLLET CHUCKS
CLEAROUT SALE**

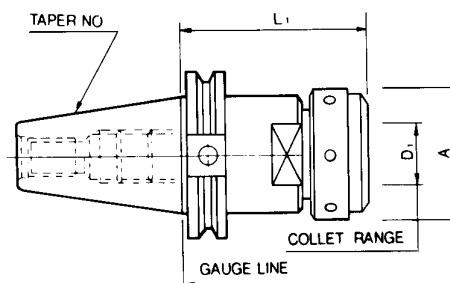

CT

Taper	Order No.	Device Type	D1 (in)	L1 (in)	A (in)
40	474-100*	CT40 – TG75 – 3.00	0.046 – 0.750	3.00	1.875
40	474-105	CT40 – TG100 – 3.25	0.063 – 1.000	3.25	2.50
40	474-106	CT40 – TG100 – 5.25	0.063 – 1.000	5.25	2.50
40	474-107	CT40 – TG100 – 7.25	0.063 – 1.000	7.25	2.50
50	474-305	CT50 – TG100 – 3.13	0.063 – 1.000	3.13	2.50
50	474-306	CT50 – TG100 – 5.13	0.063 – 1.000	5.13	2.50
50	474-307	CT50 – TG100 – 7.13	0.063 – 1.000	7.13	2.50

* While stock is still available.





TG Collet Chucks Balanced G6.3

BT & CT Flange Tools

For use with TG style
collets. See pages 2-1 and
2-2 for collet information

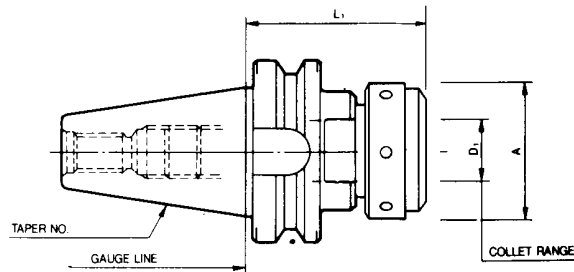

BT Taper



Taper	Order No.	Device Type	Collet Style	D ₁ Collet Range (in)	L ₁ (in)	A (in)	Max RPM
40	473-205-B*	BT40-TG100-100	TG100	0.063-1.000	3.94	2.50	15,000
40	473-206-B*	BT40-TG100-133	TG100	0.063-1.000	5.25	2.50	15,000

* While stock is still available.

**ALL TG
COLLET CHUCKS
CLEAROUT SALE**

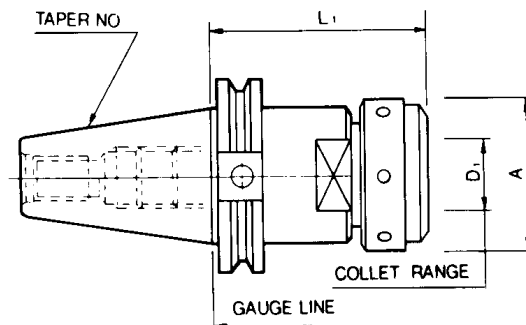

CT Taper



Taper	Order No.	Device Type	Collet Style	D ₁ Collet Range (in)	L ₁ (in)	A (in)	Max RPM
40	474-200-B*	CT40-TG75-3.00	TG75	0.046-0.750	3.00	1.875	15,000
40	474-206-B*	CT40-TG100-5.25	TG100	0.063-1.000	5.25	2.50	15,000

* While stock is still available.

NOTE: Achieving maximum rotation speed depends on the concentricity and symmetry of the cutting tool and the complete tool assembly.



TG Collet Chucks

DIN 69871-Form B

Coolant Through The Flange

CT Flange Tools

For use with TG style coolant sealed collets.
See pages 2-2 for collet information.

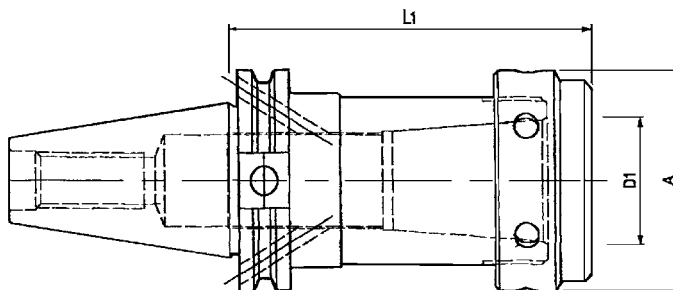

**ALL TG
COLLET CHUCKS
CLEAROUT SALE**



CT Taper

Taper	Order No.	Device Type	Collet Style	D ₁ Collet Range (in)	L ₁ (in)	A (in)	Max RPM
40	474-205-D	CT40D-TG100-3.25	TG100	0.063-1.000	3.25	2.50	15,000

NOTE: Achieving maximum rotation speed depends on the concentricity and symmetry of the cutting tool and the complete tool assembly.

R8 & NMTB-QC, TG Collet Chucks

TG Collet Chucks

NMTB tool holders are qualified for use with Erickson QC spindles.

For TG Collets, see pages 2-1 to 2-2.

**ALL TG
COLLET CHUCKS
CLEAROUT SALE**

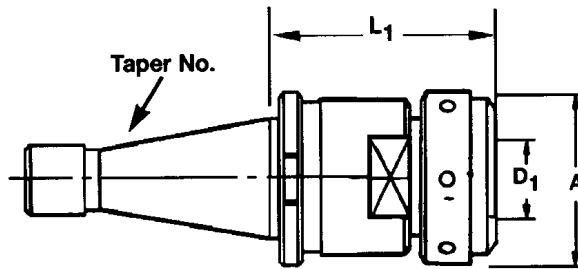

NMTB

Taper	Order No.	Device Type	D ₁ (in)	L ₁ (in)	A (in)
30	674-000*	NMTB30QC – TG75-2.50	0.046 – 0.750	2.50	1.875
30	674-005*	NMTB30QC – TG100-4.00	0.063 – 1.000	4.00	2.50
40	674-200*	NMTB40QC – TG75-2.50	0.046 – 0.750	2.50	1.875
40	674-205	NMTB40QC – TG100-3.00	0.063 – 1.000	3.00	2.50
50	674-405	NMTB50QC – TG100-3.50	0.063 – 1.000	3.50	2.50

* While stock is still available.