

Acrylic Drills

Type 183-UB 98

Auger Bits

Type 940, 941 & 942 94
 Type 950, 951 952 & 953 94

Bell Hanger Bits

Type 601 97

Bolt Remover

Bolt Extractors Set 91
 Type 420 Spiral 90
 Type 421-UB Square 90

Brad Point Drills

Type 16-UB 95
 Type 16-UB Sets 95

Carbide Tipped Holecutters

Type CHC-UB 99
 Type CHD-UB 99
 Type CHC-QR 99
 Type Ext OAL- 6-1/4" 99
 Hanging Display for CHC-QR 99

Countersinks

Type 82-UB 100
 Type 90-UB 100
 Technical Diagram 101

Combined Drills & Countersinks

Type 296 101
 Type 297 101
 Combined Drill and Counter-Sink Set . . . 101

Cutting Tool Lubricant

Type 11-UB 98

Glass & Tile Drills

Type 626 91

Hard Steel Drills

Type 602 98

Reamers

Type 50-UB Car Reamers 92
 Type 51-UB Car Reamers 92
 Type 52-UB Hex Bridge length 92
 Type 53-UB Hex Car length 92

Type 54-UB Taper Shank 93
 Type 55-UB Taper Shank 93
 Type 284-UB Hole-Hog™ 93
 Type 284-UB Hole Hog™ Sets 93

Left-Hand Spiral Drills

Type 420-AL Carded 89
 Type 240-AL 89
 Type 240-AL Sets 89

Pilot Drills

Type 491 97

Power Bits

Type 935 95
 Type 935 Sets 95

Sheeters Drills

Type 213 98

Step Drills - Multi-Diameter

Type 78-UB 96
 Type 78-UBN 96
 Type 78-QR 96
 Type 78-QRN 96
 Step Drill Sets 96

Twin End Drills

Type 490-G 97
 Type 490 97

Weldout Spotweld Drills & Sets

Type 492-D Weldout™ Spotweld . 102
 Type 493-D Weldout™ Spotweld . 102
 Type 493-DN TiN Coated 102
 Type 493-DB Carbide ALTiN Coated . 102
 Type 493-D WO-4 Set 102
 Type 492-D WO-6 Set 102



LEFT-HAND HEAVY DUTY JOBBER LENGTH DRILLS

Type 240-AL

Ultra Bor Super Premium - Left Hand Spiral

- Special Hi-Molybdenum tool steel.
- 135° split point for fast penetration and accurate starting without center punch.
- Precision ground point, flutes, body, clearance and drill diameter for the ultimate in accuracy and performance.
- Body and clearance are gold surface treated for maximum lubricity.
- Ideal for removing broken studs.

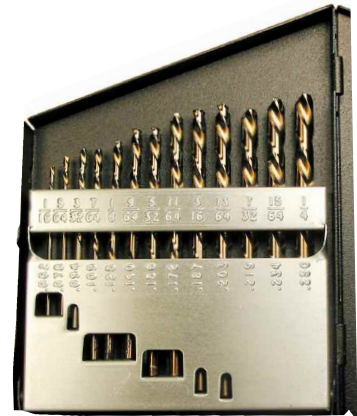

TYPE 240-AL	LEFT HAND SPIRAL
-------------	------------------

Part No.	Diameter Inches	Overall Length Inches	Flute Length Inches	Qty. per/pack
92430	1/16	1-7/8	7/8	6
23150	5/64	2	1	6
89290	3/32	2-1/4	1-1/4	6
23160	7/64	2-5/8	1-1/2	6
92440	1/8	2-3/4	1-5/8	6
92441	9/64	2-7/8	1-3/4	6
23170	5/32	3-1/8	2	6
92442	11/64	3-1/4	2-1/8	6
92450	3/16	3-1/2	2-5/16	6
92443	13/64	3-5/8	2-7/16	6
92444	7/32	3-3/4	2-1/2	6
92451	15/64	3-7/8	2-5/8	6
92460	1/4	4	2-3/4	6
92452	17/64	4-1/8	2-7/8	6
92453	9/32	4-1/4	2-15/16	6
23180	19/64	4-3/8	3-1/16	3
92470	5/16	4-1/2	3-3/16	3
92471	21/64	4-5/8	3-5/16	3
92472	11/32	4-3/4	3-7/16	3
92473	23/64	4-7/8	3-1/2	3
92480	3/8	5	3-5/8	3
92481	25/64	5-1/8	3-3/4	3
92482	13/32	5-1/4	3-7/8	3
92483	27/64	5-3/8	3-15/16	3
92490	7/16	5-1/2	4-1/16	3
92491	29/64	5-5/8	4-3/16	3
92492	15/32	5-3/4	4-5/16	3
92493	31/64	5-7/8	4-3/8	3
92500	1/2	6	4-1/2	3

TYPE 240-AL LEFT-HAND SPIRAL SETS		
-----------------------------------	--	--

8 Pcs			Qty of each
Part No.	Description of Sizes		
87650	LF-8 1/16-1/2 by 16ths		1

12 Pcs			Qty of each
Part No.	Description of Sizes		
87651	LF-12 1/16-5/16 by 32nds 3/8, 7/16 & 1/2		1

13 Pcs			Qty of each
Part No.	Description of Sizes		
87652	LF-13 1/16-1/4 by 64ths		1

15 Pcs			Qty of each
Part No.	Description of Sizes		
87654	LF-15 1/16 - 1/2 by 32nds		1

17 Pcs			Qty of each
Part No.	Description of Sizes		
87853	LF-17 1/16-1/4 by 64ths, 5/16-1/2 by 16ths		1

29 Pcs			Qty of each
Part No.	Description of Sizes		
87854	LF-29 1/16-1/2 by 64ths		1

29 Pcs - Ultra Dex			Qty of each
Part No.	Description of Sizes		
87859	LF-29P 1/16-1/2 by 64ths		1

Broken Bolt Remover Combo

Type 420-AL

- Carded left hand drill combined with spiral style screw extractor is ideal for

Part No.	Screw Extractor Number	Description of Sizes	Qty of each
30130	EX-1	3/32 LH drill	1
30140	EX-2	1/8 LH drill	1
30150	EX-3	3/16 LH drill	1
30160	EX-4	1/4 LH drill	1
30170	EX-5	5/16 LH drill	1



PRODUCT: TIPS

Bolt Remover Sets Include BOTH Left-Hand Spiral Drills and Bolt/Screw Extractors.

Specialty Tools - Left Hand Spiral Drills & Broken Bolt Extractor

HI-CARBON SCREW, STUD AND PIPE EXTRACTORS

Type 420

Screw & Pipe Extractors Hi-Carbon Steel - Spiral Style

- Remove broken screws, bolts, threaded parts, and pipes.
- Broken piece is extracted with out damage to threads.



To remove the broken threaded part:

Drill a hole in the end of the broken part (left hand spiral heavy duty drills are recommended for this drilling operation), insert extractor, then turn counterclockwise using a wrench on the exposed end of the extractor.

TYPE 420 SCREW & PIPE EXTRACTORS

Part No.	Screw Extractor Number	To remove Diameter of Screw	Diameter. of Screw Extractor Shank Point		Drill Size	No. per/pack
57100	EX-1	3/32 to 5/32	1/8	.060	5/64	5
57110	EX-2	5/32 to 7/32	3/16	.080	7/64	5
57120	EX-3	7/32 to 9/32	1/4	1/8	5/32	5
57130	EX-4	9/32 to 3/8 and 1/8 pipe	5/16	3/16	1/4	5
57140	EX-5	3/8 to 5/8 and 1/4 pipe	7/16	1/4	17/64	5
57150	EX-6	5/8 to 7/8 and 3/8 pipe	5/8	3/8	13/32	1
57160	EX-7	7/8 to 1-1/8 and 1/2 pipe	7/8	15/32	17/32	1
57170	EX-8	1-1/8 to 1-3/8 and 3/4 pipe	11/32	3/4	13/16	1
57180	EX-9	1-3/8 up and 1" pipe	1-9/32	1	1-1/8	1

TYPE 420 SCREW & PIPE EXTRACTORS - CARDED

57107	EX-1	3/32 to 5/32	1/8	.060	5/64	1
57117	EX-2	5/32 to 7/32	3/16	.080	7/64	1
57127	EX-3	7/32 to 9/32	1/4	1/8	5/32	1
57137	EX-4	9/32 to 3/8 and 1/8 pipe	5/16	3/16	1/4	1
57147	EX-5	3/8 to 5/8 and 1/4 pipe	7/16	1/4	17/64	1

Type 421-UB

Studout™ Screw, Stud and Pipe Extractors Super Premium - Square Style Forged Hi-Carbon Steel



- The square shape of these extractors gives the tools the ability to remove broken bolts, screws, and pipes with minimum deformation of the broken part.

- These extractors will not chew up or expand the object being removed.

To remove the broken threaded part: Drill a hole in the end of the broken part (left hand spiral heavy duty drills are recommended for this drilling operation), insert extractor, then turn counterclockwise using a wrench on the exposed end of the extractor.

TYPE 421-UB STUDOUT™ SCREW, STUD & PIPE EXTRACTOR

Part No.	Screw Extractor Number	To remove Diameter of Screw	Diameter. of Screw Extractor Shank Point		Drill Size	No. per/pack
70760	E-1	3/16-9/32	3/16	1/8	1/8	5
70770	E-2	9/32-11/32	1/4	11/64	3/16	5
70780	E-3	11/32-1/2	5/16	7/32	1/4	5
70800	E-4	1/2-3/4	3/8	9/32	5/16	5
70810	E-5	5/8-7/8	7/16	21/64	3/8	5
70820	E-6	7/8-1"	1/2	7/16	1/2	1
70830	E-7	1"-1-1/4	5/8	1/2	9/16	1
70860	E-8	1-1/8 - 1-1/2	3/4	9/16	5/8	1
70870	E-9	1-1/4 - 1-3/4	7/8	5/8	11/16	1

BOLT EXTRACTOR SETS / GLASS TILE

Type 420 - Bolt Extractor Set , Type 421-UB - Bolt Extractor Set

- Fast and easy stud removal
- Left-hand spiral drills often eliminate the need for use of extractor.
- Drill loosens bolt stud with counter clockwise rotation.
- 135° split point for fast penetration and accurate starting without center punch.
- Most broken studs are work hardened during the breaking process.

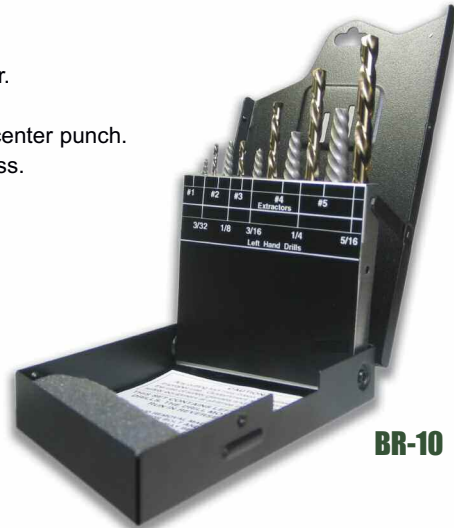

BR-10

TYPE 420 BOLT EXTRACTOR SETS - SPIRAL EXTRACTOR

SE-4N - Type 420

Part No.	Description of Sizes	Qty of each
47170	EX 2, 3, 4 & 5	1

SE-5N - Type 420

Part No.	Description of Sizes	Qty of each
47180	EX 1, 2, 3, 4 & 5	1

TYPE 420 BOLT EXTRACTOR SETS - LEFT HAND DRILL

BR-8 - Type 420 & 240-AL

Part No.	Description of Sizes	Qty of each
88550	EX 1, 2, 3, 4 + 3/32, 1/8, 3/16 & 1/4	1

BR-10 - Type 420 & 240-AL

Part No.	Description of Sizes	Qty of each
58510	EX 1, 2, 3, 4 & 5 + 3/32, 1/8, 3/16, 1/4, 5/16	1

TYPE 421-UB BOLT EXTRACTOR SETS

SQE-4 - Type 421-UB

Part No.	Description of Sizes	Qty of each
70840	EX 2, 3, 4 & 5	1

TYPE 421-UB BOLT EXTRACTOR SETS - LEFT HAND DRILL

BR-8SQ - Type 421-UB & 240-AL

Part No.	Description of Sizes	Qty of each
70850	EX 1, 2, 3 & 4 + 1/8, 3/16, 1/4 & 5/16	1

GLASS & TILE DRILLS

Type 626

Carbide Tipped with Spear Point

- Designed for drilling in glass, tile, mirrors and ceramic materials.
- Spear point allows clean penetration with reduced cutting pressure and breakout.
- Carbide tip insures long tool life.



TYPE 626 CARBIDE TIPPED

Part #	Size Inches
56510	1/8
56520	5/32
56530	3/16
56540	1/4
56550	5/16
56560	3/8
56570	1/2

Individually packaged in clear hanging tubes.

CAR REAMERS & HEX NUT REAMERS

Part #	Diameter Inches	Point Diameter	Min. Starting Hole Size	Overall Length	Shank Dia.
06390	3/8	0.250	5/16	4-5/8	3/8
06400	1/2	0.281	3/8	5-7/8	1/2
06410	9/16	0.343	7/16	5-7/8	1/2
06420	5/8	0.343	7/16	6-3/8	1/2
06430	11/16	0.375	15/32	6-3/8	1/2
06440	3/4	0.406	1/2	6-7/8	1/2
06450	13/16	0.468	35/64	6-7/8	1/2
06460	7/8	0.500	19/32	6-7/8	1/2
06470	15/16	0.585	5/8	6-7/8	1/2
06480	1"	0.594	7/8	6-7/8	1/2
06484	1-1/4	0.719	1"	6-7/8	1/2

SET	TYPE 50-UB	Includes
12270	CR-4SP	3/8, 1/2, 5/8, 3/4

Part #	Diameter Inches	Point Diameter	Min. Starting Hole Size	Overall Length	Shank Dia.
06381	5/16	0.215	17/64	4-5/8	5/16
06391	3/8	0.250	5/16	4-5/8	3/8
06501	7/16	0.250	3/8	5-7/8	7/16
06401	1/2	0.281	3/8	5-7/8	1/2
06411	9/16	0.343	7/16	5-7/8	1/2
06421	5/8	0.343	7/16	6-3/8	1/2
06432	0.652	0.375	15/32	6-3/8	1/2
06431	11/16	0.375	15/32	6-3/8	1/2
06441	3/4	0.406	1/2	6-7/8	1/2
06531	0.776	0.406	1/2	6-7/8	1/2
06451	13/16	0.468	35/64	6-7/8	1/2
06461	7/8	0.500	19/32	6-7/8	1/2
06471	15/16	0.585	5/8	6-7/8	1/2
06481	1	0.594	7/8	6-7/8	1/2
06491	1-1/16	0.807	7/8	6-7/8	1/2
06482	1-1/4	0.719	1	6-7/8	1/2

SET	TYPE 51-UB	Includes
12271	CR-4FS	3/8, 1/2, 5/8, 3/4
12281	SM-4FS	5/16, 3/8, 7/16, 1/2



TYPE 52-UB BRIDGE LENGTH

Part #	Diameter Inches	Hex Shank Inches	Flute Length	Overall Length	No. per/pack
20480	9/16	1-1/16	5-1/8	6-7/8	1
20490	5/8	1-1/16	6-1/8	7-7/8	1
20510	11/16	1-1/16	7-1/8	9-1/4	1
20520	3/4	1-1/4	7-3/8	9-3/8	1
20530	13/16	1-1/4	7-3/8	9-3/8	1
20540	7/8	1-7/16	7-3/8	9-3/8	1
20550	15/16	1-7/16	7-3/8	9-3/8	1
20560	1	1-7/16	7-3/8	9-3/8	1
20570	1-1/16	1-5/8	7-3/8	9-3/8	1
20500	1-1/8	1-5/8	7-3/8	9-3/8	1
20580	1-3/16	1-13/16	7-3/8	9-3/8	1
20590	1-5/16	2	7-3/8	10	1

Type 50-UB Car Reamers, Standard Flute 3-Flats on Shank



- These reamers are especially designed for the reaming of structural steel plates commonly found in truck frames, rail cars, bridges, and pressure vessels.
- For use in enlarging previously formed or drilled holes.
- All tools are constructed with left-hand spiral and right-hand cut.

Type 51-UB Car Reamers - Fast Spiral Hole Buster™, Super Premium 3-Flats on Shank



- Special Hi-Tungsten tool steel, gold surface treated body and clearance for maximum lubricity.
- These reamers are especially designed for the reaming of structural steel plates commonly found in truck frames, rail cars, bridges, and pressure vessels.
- The 51-UB, with the fast spiral, is the more aggressive of the two styles. It also will fit the needs of users who prefer a stop collar.

Type 52-UB - Bridge Length, Type 53-UB - Car Length Hex Nut Reamers

- Black & Gold Finish HSS- Spiral Flute

- Designed for aligning and enlarging holes in structural steel applications..
- Gold treated for maximum lubricity.

TYPE 53-UB CAR LENGTH

Part #	Diameter Inches	Hex Shank Inches	Flute Length	Overall Length	No. per/pack
35580	9/16	1-1/16	4	5-1/2	1
35590	5/8	1-1/16	4-1/2	6	1
35610	11/16	1-1/16	4-1/2	6-3/8	1
35620	3/4	1-1/4	5	7	1
35630	13/16	1-1/4	5	7	1
35640	7/8	1-7/16	5	7	1
35650	15/16	1-7/16	5	7	1
35660	1	1-7/16	5	7	1
35670	1-1/16	1-5/8	5	7	1
35600	1-1/8	1-5/8	5	7	1
35680	1-3/16	1-13/16	5	7	1
35690	1-5/16	2	5	7-7/8	1

BRIDGE REAMERS & HOLE HOG™

Type 54-UB -Straight Flute , Type 55-UB -Spiral Flute

Bridge Reamers - Straight & Spiral Flutes - Taper Shank High-Speed Steel, Surface Treated

- These special Hi-Tungsten tool steel reamers with gold surface treated body and clearance are designed to be used with Taper shank equipment.
- They are available in both straight and spiral flute configuration and are designed for heavy-duty reaming as encountered in the fabrication of structural steel assemblies, bridge erection, and ship construction.



TYPE 54-UB STRAIGHT FLUTE

Part #	Diameter Inches	Flute Length	Overall Length	Morse Taper	Qty. per/pack
81630	7/16	4-3/8	8-1/4	#2	1
81640	1/2	5-1/8	9	#2	1
81650	9/16	5-1/8	9	#2	1
81660	5/8	6-1/8	10	#2	1
81670	11/16	7-1/8	11-3/4	#3	1
81680	3/4	7-3/8	12	#3	1
81690	13/16	7-3/8	12	#3	1
81700	7/8	7-3/8	12	#3	1
81710	15/16	7-3/8	12	#3	1
81720	1	7-3/8	12	#3	1
81730	1-1/16	7-3/8	12	#3	1
81740	1-1/8	7-3/8	12	#3	1
81750	1-3/16	7-3/8	12	#3	1
81760	1-1/4	7-3/8	13	#4	1
81770	1-5/16	7-3/8	13	#4	1

TYPE 55-UB SPIRAL FLUTE

Part #	Diameter Inches	Flute Length	Overall Length	Morse Taper	Qty. per/pack
83310	7/16	4-3/8	8-1/4	#2	1
83320	1/2	5-1/8	9	#2	1
83330	9/16	5-1/8	9	#2	1
83340	5/8	6-1/8	10	#2	1
83350	11/16	7-1/8	11-3/4	#3	1
83360	3/4	7-3/8	12	#3	1
83370	13/16	7-3/8	12	#3	1
83380	7/8	7-3/8	12	#3	1
83390	15/16	7-3/8	12	#3	1
83400	1	7-3/8	12	#3	1
83410	1-1/16	7-3/8	12	#3	1
83420	1-1/8	7-3/8	12	#3	1
83430	1-3/16	7-3/8	12	#3	1
83440	1-1/4	7-3/8	13	#4	1
83450	1-5/16	7-3/8	13	#4	1

Type 284-UB

Hole Hog™ - 4-Flute Core Drill Super Premium, Flats on Shank

- This tool is designed exclusively for enlarging existing holes.
- The 4-flute design eliminates the catching and hogging-in experienced with standard S & D drills when breaking through thinner materials such as truck frames.
- These core drills may replace tapered reamers in many applications.



TYPE 284-UB FRACTIONAL

Part #	Diameter Inches	Minimum Starting Hole Size	Overall Length Inches	Flute Length Inches	Qty. per/pack
22030	3/8	1/4	4-5/16	1-7/8	1
22040	1/2	5/16	4-5/16	1-7/8	1
22060	9/16	3/8	4-5/16	1-7/8	1
22080	5/8	25/64	4-5/16	1-7/8	1
22100	11/16	7/16	4-5/16	1-7/8	1
22120	3/4	15/32	4-5/16	1-7/8	1

TYPE 284-UB SETS

SP-8HH Set contains 1 each:

284-UB core drill sizes 3/8, 1/2, 5/8 & 3/4.
250-UB drill sizes 1/4, 5/16, 25/64 & 15/32

Part No. 38880

SP-6HHL Set contains 1 each:

284-UB core drill sizes 1/2, 5/8 & 3/4.
250-UB drill sizes 5/16, 25/64 & 15/32.

Part No. 38870

SP-6HHS Set contains 1 each:

284-UB core drill sizes: 3/8, 1/2 & 5/8.
250-UB drill sizes 1/4, 5/16 & 25/64

Part No. 38860

Hole Hog™ Sets
1/2" Shank (3-flats on Shank) 4-Flute Core Drill

Ultra Bor Super Premium

- A selection of core drills and companion (minimum starting hole size) pilot drills in a black steel index.



AUGER BITS CARBIDE

Type 940 -12" Bits, Type 941 -18" Bits, Type 942 -24" Bits Carbide-Tipped Auger Bit

- A carbide cutting tip combined with a hardened steel cutting edge, allows it to bore holes in all types of wood quickly.
- A clean, smooth hole is provided.
- Requires less torque to operate and can be used with electric, air or gasoline powered drill motors, and impact wrenches.
- The carbide cutter is brazed onto the steel body and the hardened steel cutting edge can be resharpened.



TYPE 940 12" AUGER BITS

Part No.	Description of Sizes
51300	1/2
51310	9/16
51320	5/8
51330	11/16
51340	3/4
51350	13/16
51360	7/8
51370	15/16
51380	1"
51390	1-1/16
51400	1-1/8

TYPE 941 18" AUGER BITS

Part No.	Description of Sizes
51410	1/2
51420	9/16
51430	5/8
51440	11/16
51450	3/4
51460	13/16
51470	7/8
51480	15/16
51490	1"
51500	1-1/16
51510	1-1/8

TYPE 942 24" AUGER BITS

Part No.	Description of Sizes
51520	1/2
51530	9/16
51540	5/8
51550	11/16
51560	3/4
51570	13/16
51580	7/8
51590	15/16
51600	1"
51610	1-1/16
51620	1-1/8

STANDARD WOOD AUGERS

Types 950 -9" Bits, Type 951 -16" Bits, Type 952 -18" Bits, Type 953 -24" Bits

- High quality auger bits with hex shanks produced from alloy tool steel.
- For deep drilling wood applications, quickly and easily drill holes in all types of wood products.



TYPE 950 9" AUGER BITS

Part No.	Description of Sizes
53200	3/8"
53210	1/2"
53220	9/16"
53230	5/8"
53240	11/16"
53250	3/4"
53260	7/8"
53270	15/16"
53280	1"
53290	1-1/8"

TYPE 951 16" AUGER BITS

Part No.	Description of Sizes
53300	3/8"
53310	1/2"
53320	9/16"
53330	5/8"
53340	11/16"
53350	3/4"
53360	7/8"
53370	15/16"
53380	1"
53390	1-1/8"

TYPE 952 18" AUGER BITS

Part No.	Description of Sizes
53400	3/8"
53410	1/2"
53420	9/16"
53430	5/8"
53440	11/16"
53450	3/4"
53460	7/8"
53470	15/16"
53480	1"
53490	1-1/8"

TYPE 953 24" AUGER BITS

Part No.	Description of Sizes
53500	3/8"
53510	1/2"
53520	9/16"
53530	5/8"
53540	11/16"
53550	3/4"
53560	7/8"
53570	15/16"
53580	1"
53590	1-1/8"

BRAD POINT DRILLS

Type 16-UB

Jobber Length - Burrouter™ Brad Point Super Premium

- These high performance drills made from Hi-Moly tool steel will cut holes in wood or plastics and leave no burr.
- The special **BURROUT™** point cuts at the circumference of the hole to avoid the break through burr problems common with standard point drills.



TYPE 16-UB FRACTIONAL

Part No.	Diameter Inches	Overall Length Inches	Flute Length Inches	Qty. per/pack
01041	5/64	2	1	12
01051	3/32	2 1/4	1 1/4	12
01061	7/64	2 5/8	1 1/2	12
01071	1/8	2 3/4	1 5/8	12
01081	9/64	2 7/8	1 3/4	12
01091	5/32	3 1/8	2	12
01101	11/64	3 1/4	2 1/8	12
01111	3/16	3 1/2	2 5/16	12
01131	7/32	3 3/4	2 1/2	12
01151	1/4	4	2 3/4	12
01191	5/16	4 1/2	3 3/16	6
01231	3/8	5	3 5/8	6
01271	3/8	5 1/2	4 1/16	6
01311	3/8	6	4 1/2	6

TYPE 16-UB SETS

Burrouter™

BF-10

Part No.	Description of Sizes	Qty. of each
42001	5/64-3/16 by 64ths + 7/32, 1/4	1

BF-14

Part No.	Description of Sizes	Qty. of each
42031	5/64-3/16 by 64ths + 7/32, 1/4-1/2 by 16ths	1

POWER BITS

Type 935

TYPE 935 1/4" HEX SHANK

Part No.	Diameter Inches	Qty. per/pack
52005	1/4	1
52015	5/16	1
52025	3/8	1
52035	7/16	1
52045	1/2	1
52055	9/16	1
52065	5/8	1
52075	11/16	1
52085	3/4	1
52095	13/16	1
52105	7/8	1
52115	15/16	1
52125	1 INCH	1
52135	1-1/8	1
52145	1-1/4	1
52155	1-3/8	1
52165	1-1/2	1

Quick Release 1/4" Hex Shank - Power Bits

- Cuts clean accurate holes in all soft and hard woods plus foam core, plastic, many non-metallic building siding, and foam insulation.

TYPE 935 1/4" HEX SHANK SETS

EASY-CUT 4 PIECE SET

One each: 3/8, 1/2, 5/8 & 3/4 in plastic pouch.
Part No. 52185

EASY-CUT 6 PIECE SET

One each: 3/8, 1/2, 5/8, 3/4, 7/8 & 1" in plastic pouch.
Part No. 52195

EASY-CUT 13 PIECE SET

One each: 1/4, 5/16, 3/8, 7/16, 1/2, 9/16, 5/8 11/16, 3/4, 13/16, 7/8, 15/16 & 1" in plastic pouch.
Part No. 52205

EASY-CUT 6" - 12" EXTENSION

For all bits with 1/4" shanks.
For those jobs that require extra reach.
With allen wrench.

EXTENSIONS

Part No.	Size	Qty. per/pack
27555	6"	1
52175	12"	1



Quick Release 1/4" Hex Shank



Specialty Tools

STEP DRILLS



Type 78-UB 3-Flatted Shank
Type 78-UBN - TiN Coated
Type 78-QR Quick Release
Type 78-QRN - TiN Coated Quick Release

Ultra Bit™ Multi-Diameter 3-Flats on Shank

- Special Axial and Radial flute design speed work piece penetration.
- Dual flute construction drills clean accurate holes in thin materials, quickly and easily.
- Use for all thin metals, rigid plastics, wood or composite materials with a thickness equal to or less than the step thickness.
- Split point self centers and easily starts with no pilot hole required
- Made in the U.S.A.

TYPE 78-UB 3-FLATTED SHANK

Part#	Size	Hole Sizes	No. Range	Shank Size	Step Increments	Step Thickness
00700	1	13	1/8 - 1/2	1/4	1/32	1/8
00704	2	8	9/16 - 1"	3/8	1/16	5/32
00703	3	9	1/4 - 3/4	3/8	1/16	5/32
00701	4	6	3/16 - 1/2	1/4	1/16	3/8
00702	8	12	3/16 - 7/8	3/8	1/16	1/8
00714	7	11	1/4 - 7/8	3/8	1/16	1/16
00770	9	3	7/8 - 1-7/32	3/8	7/8	----
00713	11	2	7/8 - 1-1/8	3/8	27/64	9/64
00711	12	10	1/4 - 1-3/8	3/8	1/8	*SEE NOTE
00710	13/16	10	13/16 - 1-3/8	1/2	1/32	5/32
00719	1/4 A	16	1/4 - 1-1/8	3/8	1/16	1/16

NOTE: Part No. 00711 — 7/8", 1-1/8" (1/2 and 3/4" conduit)

HANGING TUBES STEP DRILLS

00693		1/2" - Single hole				
00694		3/8" - Single hole				

SETS - TYPE 78-UB STEP DRILLS

00721	1/8 - 1/2, 3/16 - 1/2, & 3/16 - 7/8"	(#1, #4, #8)
00731	1/8 - 1/2, 3/16 - 1/2, & 9/16 - 1"	(#1, #4, #2)
00741	1/8 - 1/2, 3/16 - 1/2, & 1/4 - 3/4"	(#1, #4, #3)
00781 4pcs.	1/8 - 1/2, 1/4 - 3/4, 1/4 - 7/8 7/8 - 1-1/8"	(#1, #3, #7, #11)



TYPE 78-QR HEX SHANK STEP DRILLS

Part#	Size	Hole Sizes	No. Range	Shank Size	Step Increments	Step Thickness
01401	1	13	1/8 - 1/2"	1/4"	1/32"	1/8"
01411	2	8	9/16 - 1"	3/8"	1/16"	5/32"
01404	3	9	1/4 - 3/4	1/4"	1/16"	5/32"
01402	4	6	3/16 - 1/2"	1/4"	1/16"	3/8"
01412	7	11	1/4 - 7/8"	1/4"	1/16"	1/16"
01403	8	12	3/16 - 7/8"	1/4"	1/16"	1/8"
01419	9	3	7/8 - 1-7/32"	3/8"	7/8"	----
01409	11	2	7/8 - 1-1/8"	1/4"	27/64"	9/64"
01414	12	10	1/4 - 1-3/8"	3/8	1/8	*SEE NOTE
01413	1/4 A	16	1/4 - 1-1/8"	1/4"	1/16"	1/16"

NOTE: Part No. 01414 ---- 7/8", 1-1/8" (1/2 and 3/4" conduit)

SETS - TYPE 78-QR STEP DRILLS

01441	1/8 - 1/2, 3/16 - 1/2, & 3/16 - 7/8	(#1, #4, #8)
01451	1/8 - 1/2, 3/16 - 1/2, & 1/4 - 3/4	(#1, #4, #3)
01461	1/8 - 1/2, 3/16 - 7/8, 7/8 - 1 - 1/8	(#1, #4, #11)



TYPE 78-UBN TiN COATED

Part#	Size	Hole Sizes	No. Range	Shank Size	Step Increments	Step Thickness
69130	1	13	1/8 - 1/2	1/4	1/32	1/8
69180	2	8	9/16 - 1"	3/8	1/16	5/32
69160	3	9	1/4 - 3/4	3/8	1/16	5/32
69140	4	6	3/16 - 1/2	1/4	1/16	3/8
69170	7	11	1/4 - 7/8	3/8	1/16	1/16
69150	8	12	3/16 - 7/8	3/8	1/16	1/8
69270	9	3	7/8 - 1-7/32	3/8	7/8	----
69200	11	2	7/8 - 1 - 1/8	3/8	27/64	9/64
69220	12	10	1/4 - 1 - 3/8	3/8	1/8	SEE NOTE
69190	13/16	10	13/16 - 1 - 3/8	1/2	1/32	5/32
69210	1/4 A	16	1/4 - 1-1/8	3/8	1/16	1/16

NOTE: Part #69220 ---- 7/8", 1-1/8" (1/2 and 3/4" conduit)

SETS - TYPE 78-UBN TiN COATED

69230	1/8 - 1/2, 3/16 - 1/2, & 3/16 - 7/8"	(#1, #4, #8)
69240	1/8 - 1/2, 3/16 - 1/2, & 9/16 - 1"	(#1, #4, #2)
69250	1/8 - 1/2, 3/16 - 1/2, & 1/4 - 3/4"	(#1, #4, #3)
68781 4pcs.	1/8 - 1/2, 1/4 - 3/4, 1/4 - 7/8 7/8 - 1-1/8"	(#1, #3, #7, #11)



TYPE 78-QRN TiN COATED

Part#	Size	Hole Sizes	No. Range	Shank Size	Step Increments	Step Thickness
68491	1	13	1/8 - 1/2"	1/4"	1/32"	1/8"
68534	2	8	9/16 - 1"	3/8"	1/16"	5/32"
68521	3	9	1/4 - 3/4	1/4"	1/16"	5/32"
68501	4	6	3/16 - 1/2"	1/4"	1/16"	3/8"
68541	7	11	1/4 - 7/8"	1/4"	1/16"	1/16"
68511	8	12	3/16 - 7/8"	1/4"	1/16"	1/8"
68554	9	3	7/8 - 1-7/32"	3/8"	7/8"	----
68531	11	2	7/8 - 1-1/8"	1/4"	27/64"	9/64"
68524	12	10	1/4 - 1-3/8"	3/8	1/8	*SEE NOTE
68551	1/4 A	16	1/4 - 1-1/8"	1/4"	1/16"	1/16"

NOTE: Part No. 68524 ---- 7/8", 1-1/8" (1/2 and 3/4" conduit)

SETS - TYPE 78-QRN TiN COATED

68561	1/8 - 1/2, 3/16 - 1/2 & 3/16 - 7/8	(#1, #4, #8)
68571	1/8 - 1/2, 3/16 - 1/2 & 1/4 - 3/4	(#1, #4, #3)
68581	1/8 - 1/2, 3/16 - 1/2 & 7/8 - 1-1/8	(#1, #4, #11)

All tools individually packed in clear tubes

TWIN END & PILOT DRILLS, BELL HANGER BITS

TYPE 490-G -ULTRA BOR SUPER PREMIUM, TYPE 490 -HEAVY DUTY

Twin End - Ultra Bor Super Premium 135° Split Point

- Special Hi-Molybdenum tool steel, gold surface treated for maximum lubricity.
- 135° split point for fast penetration and accurate starting without a center punch.



Twin End - Heavy-Duty -135° Split Point

- This twin end drill has wide applications in drilling any thin sheet metal or wood.
- Automotive body shops will find twin end drills especially productive.
- Black Oxide finish.



TYPE 490-G FRACTIONAL

Part No.	Diameter Inches	Overall Length Inches	Flute Length Inches	Qty. per/pack
95090	3/32	1-3/4	9/16	12
95080	7/64	1-15/16	5/8	12
95980	1/8	1-15/16	5/8	12
95070	9/64	2	5/8	12
95060	5/32	2-1/8	5/8	12
95050	3/16	2-5/16	5/8	12
95040	7/32	2-9/16	3/4	12
95030	1/4	2-5/8	13/16	12

TYPE 490 FRACTIONAL

Part No.	Diameter Inches	Overall Length Inches	Flute Length Inches	Qty. per/pack
28470	3/32	1-3/4	9/16	12
28480	7/64	1-15/16	5/8	12
28490	1/8	1-15/16	5/8	12
28500	9/64	2	5/8	12
28510	5/32	2-1/8	5/8	12
28530	3/16	2-5/16	5/8	12
28550	7/32	2-9/16	3/4	12
28570	1/4	2-5/8	13/16	12

TYPE 490-G WIRE

Part No.	Diameter Wire Gauge	Overall Length Inches	Flute Length Inches	Qty. per/pack
95020	10	2-5/16	5/8	12
95010	11	2-5/16	5/8	12
95000	20	2-1/8	5/8	12
94990	30	2	5/8	12

TYPE 490 WIRE

Part No.	Diameter Wire Gauge	Overall Length Inches	Flute Length Inches	Qty. per/pack
27940	10	2-5/16	5/8	12
27950	11	2-5/16	5/8	12
28040	20	2-1/8	5/8	12
28140	30	2	5/8	12

PILOT DRILLS

Type 491

Pilot Drills For HSS Hole Saws



135° Split Point

Part #	Size Inches	Description	Diameter Inches	Overall Length Inches	Qty. per/pack
95100	1/4 x 4	Universal pilot with two whistle notch flats. Fits most hole saws needing 4" length - Bright finish	1/4	4	12
95101	1/4 x 3	Fits most arbors with one set screw: Lennox, Starrett, Morse, Milwaukee & more. One flat on shank. Bright finish.	1/4	3	12
95102	1/4 x 4L	Three long flats on shank allow for set screw and eliminate slippage through the arbor drive. (Replaces Lennox and others). Surface treated.	1/4	4	12
95103	1/4 x 3L	Same as 95101 except surface treated. (Replaces Lennox and others).	1/4	3	12
95104	1/4 x 4-1/4L	Three long flats on shank allow for set screw and eliminate slippage through the arbor drive. (Replaces Lennox L-series). Black Surface treated.	1/4	4-1/4"	12

BELL HANGER BITS

Type 601

Carbide Tipped, Alloy Steel Shanks

- Flutes are designed for quick chip clearance.
- Recommended for all telephone, electrical, cable T.V. installers.
- Excellent for drilling through wood, metal lathe, plaster, wallboard.



(Hole in flute for pulling wire)

Part No.	Diameter Inches	Shank Diameter Inches	Overall Length Inches	Qty. per/pack
32000	1/4	1/4	12	1
32010	5/16	5/16	12	1
32020	3/8	3/8	12	1
32030	1/2	3/8	12	1
32040	1/4	1/4	18	1
32050	5/16	5/16	18	1
32060	3/8	3/8	18	1
32070	1/2	3/8	18	1
32080	1/4	1/4	24	1
32090	5/16	5/16	24	1

Part No.	Diameter Inches	Shank Diameter Inches	Overall Length Inches	Qty. per/pack
32100	3/8	3/8	24	1
32110	1/2	3/8	24	1
32120	1/4	1/4	36	1
32130	5/16	5/16	36	1
32140	3/8	3/8	36	1
32150	1/2	3/8	36	1
32160	1/4	1/4	48	1
32170	5/16	5/16	48	1
32180	3/8	3/8	48	1
32190	1/2	3/8	48	1



Specialty Tools

ACRYLIC, HARD STEEL, SHEETERS DRILLS & CUTTING TOOL LUBRICANT

Type 183-UB

Acrylic Drills with Chipfree™ Point Ultra Bor Super Premium

- Super **CHIPFREE™** point is precision ground at a 60° angle for gradual penetration to avoid cracking and chipping of the acrylic material.
- Special 0° rake angle on cutting edge eliminates "grabbing" when drill breaks through plastic, acrylic, or laminate surfaces.
- All sizes over 1/4" have 1/4" shanks.



TYPE 183-UB FRACTIONAL

Part No.	Diameter Inches	Overall Length Inches	Flute Length Inches	Qty. per/pack
32260	3/32	2-1/4	1-5/16	12
31500	1/8	2-1/2	1-3/8	12
31510	5/32	2-7/8	2-3/16	12
31520	3/16	3-3/16	2	12
32220	7/32	3-3/4	2-9/16	12
31530	1/4	3-9/16	2-5/16	12
32240	9/32	3-9/16	2	12
31540	5/16	3-5/8	2-3/16	6
32290	11/32	4-1/32	2-3/8	6
31550	3/8	3-5/8	2-9/16	6
32460	13/32	4-1/32	2-3/4	6
31560	7/16	4	2-15/16	6
32470	15/32	4-7/8	3-1/8	6
31570	1/2	4-1/4	3-1/4	6

Type 602

Hard Steel Drills Carbide Tipped, Straight Flute

- These drills are made for use in drilling hardened steel in the range of **48 to 65 Rockwell C**.
- Used for drilling broken studs, springs, bolts, die sections, broken easy outs, extra tough or exotic metals, and brake drums.



TYPE 602 FRACTIONAL

Part No.	Diameter Inches	Shank Diameter Inches	Overall Length Inches	Qty. per/pack
32300	1/8	1/8	2-3/4	1
32310	5/32	5/32	3	1
32320	11/64	11/64	3	1
32330	3/16	3/16	3	1
32340	7/32	7/32	4	1
32350	1/4	1/4	4	1
32360	1/4	1/4	6	1
32370	9/32	9/32	4	1
32380	5/16	1/4	4	1
32390	5/16	5/16	6	1
32400	3/8	1/4	4	1
32410	3/8	3/8	6	1
32420	7/16	3/8	6	1
32430	1/2	1/2	6	1
32440	9/16	1/2	6	1
32450	5/8	1/2	6	1

Type 213

Sheeters Drill - Black Surface Treated

Heavy-duty 135° split point high-speed steel drill is excellent for drilling sheet metal and corrugated construction panels.



TYPE 213 WIRE

Part #	Diameter Wire Gauge	Overall Length Inches	Flute Length Inches	Qty. per/pack
27010	1	3	1-5/16	12
27030	1	4-1/2	1-5/16	12
27040	1	6	1-5/16	12

CUTTING TOOL LUBRICANT

Type 11-UB

Ultra S/P™ Super Premium

High Viscosity.

- Super concentrated no run formula.
- Clings to vertical surfaces for continual lubrication.
- Virtually smoke free in even the most heat prone applications.
- Contains no ozone depleting substances.

This fluid will extend tool life and yield a super machined finish.



TYPE 11-UB ULTRA S/P™

Part No.	Size MM	Bottles Per Case	Weight Per Case
96050	12 - 4 OZ.	12	4.4 Lbs./2 Kgs.
96060	48 - 4 OZ.	48	18 Lbs./8.2 Kgs.
96070	12 - 16 OZ.	12	15 Lbs./6.8 Kgs.

Part No. 96071 is a self selling display with an attractive attention getting decal applied to the inside of the display flap. Dispose of display when empty.



CARBIDE TIPPED HOLECUTTERS

Type CHC-UB, Type CHD-UB, Type CHC-QR

Carbide Tipped Holecutters Ultra Bor Super Premium

- 3-flatted shank for keyless chucks.
- Produces overlapping and interrupted holes easily
- Cuts 3 times faster than bi-metal hole saws.

TYPE CHC-UB HOLECUTTERS

CUTS UP TO 3/16"

THIN MATERIAL

Part#	Diameter Inches	Shank Diameter	Qty. per/pack
62000	9/16	3/8"	1
62010	5/8	3/8"	1
62020	11/16	3/8"	1
62030	3/4	3/8"	1
62040	13/16	3/8"	1
62050	7/8	3/8"	1
62060	15/16	3/8"	1
62070	1"	3/8"	1
62080	1-1/16	3/8"	1
62090	1-1/8	3/8"	1
62100	1-3/16	3/8"	1
62110	1-1/4	3/8"	1
62120	1-5/16	3/8"	1
62130	1-3/8	3/8"	1
62140	1-7/16	3/8"	1
62150	1-1/2	3/8"	1
62160	1-9/16	3/8"	1

Part#	Diameter Inches	Shank Diameter	Qty. per/pack
62170	1-5/8	3/8"	1
62180	1-11/16	3/8"	1
62190	1-3/4	3/8"	1
62200	1-13/16	3/8"	1
62210	1-7/8	3/8"	1
62220	1-15/16	3/8"	1
62230	2"	3/8"	1
62240	2-1/16	3/8"	1
62250	2-1/8	3/8"	1
62260	2-3/16	3/8"	1
62270	2-1/4	3/8"	1
62280	2-5/16	3/8"	1
62290	2-3/8	3/8"	1
62300	2-7/16	3/8"	1
62310	2-1/2	3/8"	1
62320	2-9/16	3/8"	1
62330	2-5/8	3/8"	1

Part#	Diameter Inches	Shank Diameter	Qty. per/pack
62340	2-11/16	1/2"	1
62350	2-3/4	1/2"	1
62360	2-13/16	1/2"	1
62370	2-7/8	1/2"	1
62380	2-15/16	1/2"	1
62390	3"	1/2"	1
62400	3-1/4	1/2"	1
62410	3-1/2	1/2"	1
62420	3-3/4	1/2"	1
62430	4"	1/2"	1
62440	4-1/4	1/2"	1
62450	4-1/2	1/2"	1
62460	4-3/4	1/2"	1
62470	5"	1/2"	1
62480	PILOT DRILL		1
62490	SCREW		1
62500	SPRING		1

Type CHD-UB

Deephole Carbide Tipped Holecutters Ultra Bor Super Premium

- 3-flatted shank for keyless chucks.
- Produces overlapping and interrupted holes easily
- Cuts 3 times faster than bi-metal hole saws.



TYPE CHD DEEP HOLECUTTERS

CUTS UP TO 1"

THICK MATERIAL

Part#	Diameter Inches	Shank Diameter	Qty. per/pack
63990	9/16"	3/8"	1
64000	5/8"	3/8"	1
64010	11/16"	3/8"	1
64020	3/4"	3/8"	1
64030	13/16"	3/8"	1
64040	7/8"	3/8"	1
64050	15/16"	3/8"	1
64060	1"	3/8"	1
64070	1-1/16"	3/8"	1
64080	1-1/8"	3/8"	1
64090	1-3/16"	3/8"	1
64100	1-1/4"	3/8"	1
64110	1-5/16"	3/8"	1
64120	1-3/8"	3/8"	1
64130	1-7/16"	3/8"	1
64140	1-1/2"	3/8"	1
64150	1-9/16"	3/8"	1

Part#	Diameter Inches	Shank Diameter	Qty. per/pack
64160	1-5/8"	3/8"	1
64170	1-11/16"	3/8"	1
64180	1-3/4"	3/8"	1
64190	1-13/16"	3/8"	1
64200	1-7/8"	3/8"	1
64210	1-15/16"	3/8"	1
64220	2"	3/8"	1
64240	2-1/16"	3/8"	1
64250	2-1/8"	3/8"	1
64260	2-3/16"	3/8"	1
64270	2-1/4"	3/8"	1
64280	2-5/16"	3/8"	1
64290	2-3/8"	3/8"	1
64330	2-7/16"	3/8"	1
64340	2-1/2"	3/8"	1
64350	2-9/16"	3/8"	1
64360	2-5/8"	3/8"	1

Part#	Diameter Inches	Shank Diameter	Qty. per/pack
64370	2-11/16"	1/2"	1
64380	2-3/4"	1/2"	1
64390	2-13/16"	1/2"	1
64400	2-7/8"	1/2"	1
64410	2-15/16"	1/2"	1
64420	3"	1/2"	1
64430	3-1/4"	1/2"	1
64440	3-1/2"	1/2"	1
64450	3-3/4"	1/2"	1
64460	4"	1/2"	1
64470	4-1/4"	1/2"	1
64480	4-1/2"	1/2"	1
64490	4-3/4"	1/2"	1
64231	PILOT DRILL		1
62490	SCREW		1
62530	SPRING		1

Type CHC-QR

1/4" Quick Release

Part No.	Diameter Inches	Shank Diameter	Qty. per/pack
83470	5/8"	1/4"	1
83480	11/16"	1/4"	1
83490	3/4"	1/4"	1
83500	13/16"	1/4"	1
83510	7/8"	1/4"	1
83520	15/16"	1/4"	1
83530	1"	1/4"	1
83540	1-1/16"	1/4"	1
83550	1-1/8"	1/4"	1
83560	1-3/16"	1/4"	1
83580	1-1/4"	1/4"	1
83590	1-5/16"	1/4"	1
83600	1-3/8"	1/4"	1
83950	PILOT DRILL		1
83960	SCREW		1
83970	SPRING		1



Type EXT

Carbide Tipped Holecutter - Extension

Includes "Allen Wrench" (For CHC-UB & CHD-UB Holecutter only)



Part #	Bore/Shank	Diameter	Overall Length	Ext Length	Qty. per/pack
62710	3/8"	7/8"	6-1/4"	5 inches	1
62720	1/2"	7/8"	6-1/4"	5 inches	1

Type CHC-18

CARBIDE TIPPED HOLECUTTER HANGING DISPLAY

Contents	Size	# of Each
CHC-UB	13/16, 7/8, 15/16, 1", 1-1/16	1
Depth of cut	3/16" 1-1/8, 1-3/16, 1-1/4, 1-3/8	
CHD-UB	13/16, 7/8, 15/16, 1", 1-1/16	1
Depth of cut	1" 1-1/8, 1-3/16, 1-1/4, 1-3/8	

Display Rack 16" width x 27" height 1
(Display Rack Only Part # 14120)

COUNTERSINKS

Type 82-UB -Piloted , Type 82-UB -Pilotless , Type 90-UB -Deburring

Type 82-UB Chatterproof™ Countersinks Super Premium
 Type 90-UB Chatterproof™ Deburring Tools Super Premium



Type 82-UB - Piloted



Type 82-UB - Pilotless



Type 90-UB - Deburring

Special Hi-Molybdenum tool steel, gold surface treated for maximum lubricity.

These high performance, flute-less tools are:

- Free cutting - for ease of use.
- Designed for fast stock removal.
- Chatterproof - for a micro smooth finish.
- Easily resharpened - for extra long life.
- Available in a wide selection of styles.
- Recommended for smooth finishes on metal, plastic and wood applications.
- Made in the U.S.A.

TYPE 82-UB 82° PILOTED COUNTERSINK

Part No.	Size	Style	Screw Size	Shank Diameter		Overall Length		D	E	F	No. per/pack
				A	B	C					
67010	CS1/4	1	1/4	1/4	3/8	2	33/64	1	5/32		1
67020	CS1/4A	1	1/4	17/64	3/8	2	33/64	1	5/32		1
67030	CS5/16	1	5/16	5/16	3/8	2-3/16	41/64	1-3/16	5/32		1
67040	CS5/16A	1	5/16	21/64	3/8	2-3/16	41/64	1-3/16	5/32		1
67050	CS3/8	1	3/8	3/8	1/2	2-5/8	49/64	1-3/8	5/32		1
67060	CS3/8A	1	3/8	25/64	1/2	2-5/8	49/64	1-3/8	5/32		1
67070	CS7/16	1	7/16	7/16	1/2	2-3/4	53/64	1-1/2	7/32		1
67080	CS7/16A	1	7/16	29/64	1/2	2-3/4	53/64	1-1/2	7/32		1
67090	CS1/2	1	1/2	1/2	1/2	2-13/16	15/16	1-9/16	1/4		1
67100	CS1/2A	1	1/2	33/64	1/2	2-13/16	15/16	1-9/16	1/4		1

See next page for technical diagram

TYPE 82-UB 82° PILOTLESS COUNTERSINK

Part No.	Size	Style	Diameter of Cut		Screw Size	Shank Diameter		Overall Length		No. per/pack
			Min	Max		B	C	D	E	
67110	CS073	3	0.073	15/64		1/4	1-3/4			1
67120	CS3/16	2	3/16	17/32		1/4	1-15/16	9/16	1	1
67130	CS307	1	0.307	25/32		1/2	2-5/8	13/16	1-3/8	1
67140	CS307A	1	0.307	25/32		1/4	2-1/16	13/16	1-1/4	1
67150	CS431	2	0.431	7/8		1/2	2-13/16	1-1/8	1-9/16	1
67160	CS1/2B	1	1/2	1-15/32		1/2	3-1/2	1-1/2	2-1/8	1
67170	CS55	2			No. 4	1/4	1-1/2	17/64	5/8	1
67180	CS65	2			No. 6	1/4	1-1/2	19/64	5/8	1
67190	CS85	2			No. 8	1/4	1-5/8	11/32	3/4	1
67200	CS105	2			No. 10	1/4	1-5/8	25/64	3/4	1

See next page for technical diagram

TYPE 90-UB 90° DEBURRING TOOLS

Part No.	Size	Style	Diameter of Cut		Shank Diameter	Overall Length		D	E	No. per/pack
			Min	Max		B	C			
67210	DB1/64	3	1/64	11/64	3/16	1-1/2				1
67220	DB1/16	3	1/16	11/64	3/16	1-1/2				1
67230	DB1/8	3	1/8	15/64	1/4	1-3/4				1
67240	DB5/32	2	5/32	13/32	1/4	1-11/16	7/16	13/16		1
67250	DB3/16	2	3/16	17/32	1/4	1-7/8	9/16	1		1
67260	DB5/16	2	5/16	25/32	1/2	2-19/32	13/16	1-3/8		1
67270	DB5/16C	2	5/16	25/32	1/4	2-1/32	13/16	1-5/32		1
67280	DB9/16	2	9/16	1-3/32	1/2	2-13/16	1-1/8	1-9/16		1
67290	DB1/2	2	1/2	1-15/32	1/2	3-1/2	1-1/2	2-1/8		1

See next page for technical diagram

COUNTERSINK TECHNICAL DIAGRAM

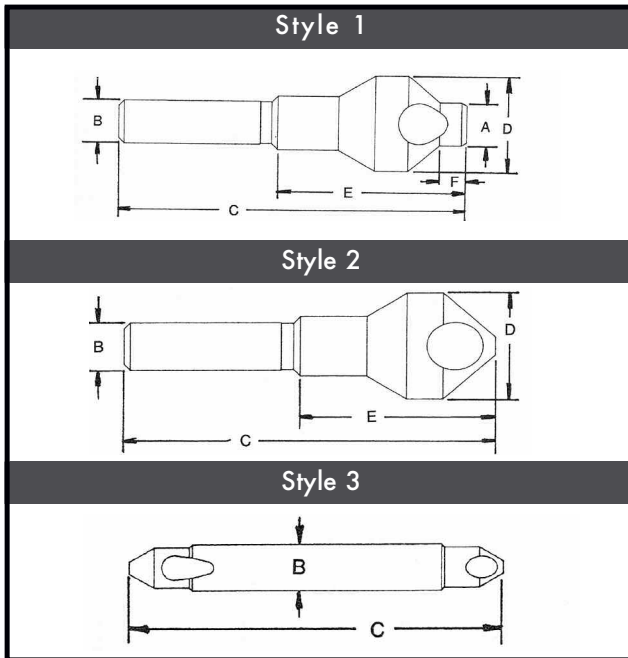

TYPE 82-UB & TYPE 90-UB SETS

Part No.	Description of Sizes
SP-4CS 10440	82-UB C/S sizes: CS55, CS65, CS85, CS105
SP-4ACS 10442	82-UB C/S sizes: CS65, CS85, CS105, CS3/16
SP-6DB 10450	90-UB D/B sizes: DB1/16, DB1/8, DB5/32, DB3/16, DB5/16 & DB9/16
SP-9CS 10443	82-UB C/S sizes: CS55, CS65, CS85, CS105, CS1/4, CS5/16, CS3/8, CS7/16, & CS1/2



COMBINED DRILLS & COUNTERSINK

Type 296 -Plain, Type 297 -Bell

Type 296

Drill ends are of equal diameter. The included angle is 60°.

Type 297

- The included angles are 60° and 120°. The diameter at the intersection of these two angles is the bell diameter.
- The small 120° angular chamfer protects the edges of the center hole.



TYPE 296 PLAIN COUNTERSINKS

Part No.	Size	Dia. of Body Inches	Dia. & Length of drills	Overall Length Inches	Std. Pack
26760	00	1/8	.025x.030	1-7/32	6
26770	0	1/8	1/32x.038	1-7/32	6
26780	1	1/8	3/64x3/64	1-1/4	6
26790	2	3/16	5/64x5/64	1-7/8	6
26800	3	1/4	7/64x7/64	2	6
26810	4	5/16	1/8x1/8	2-1/8	6
26820	5	7/16	3/16x3/16	2-3/4	6
26830	6	1/2	7/32x7/32	3	6
26840	7	5/8	1/4x1/4	3-1/4	1
26850	8	3/4	5/16x5/16	3-1/2	1

TYPE 297 BELL COUNTERSINKS

Part No.	Size	Dia. of Body Inches	Dia. & Length of drills	Dia. of Bell Inches	Overall Length Inches	Std. Pack
26860	11	1/8	3/64x3/64	.100	1-1/4	6
26870	12	3/16	1/16x1/16	.150	1-7/8	6
26880	13	1/4	3/32x3/32	.200	2	6
26890	14	5/16	7/64x7/64	.250	2-1/8	6
26900	15	7/16	5/32x5/32	.350	2-3/4	6
26910	16	1/2	3/16x3/16	.400	3	6
26920	17	5/8	7/32x7/32	.500	3-1/4	1
26930	18	3/4	1/4x1/4	.600	3-1/2	1

COMBINED DRILL AND COUNTER-SINK - SET

26861 5pcs. Set Sizes: 1, 2, 3, 4 and 5

SUPER COBALT - WELDOUT™ CARBIDE SPOTWELD DRILLS

Types 492-D & 493-D

Weldout™ Spotweld
Super Cobalt High-Speed Steel
Gold Finish - Heavy-Duty Spur Point

- This rugged high performance drill is designed to effectively cut auto body panel spot welds.
- High red hot hardness of cobalt steel permits speeds 30% greater than H.S.S. drills.

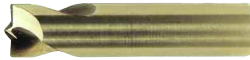

TYPE 492-D WELDOUT™ SPOTWELD

Part No.	Diameter MM	Approx Spotweld Size, Inches	Overall Length Inches	Flat Length Inches	Qty. per/pack
66420	6.5mm	1/4	1.56	.44	5
37240	6.5mm	1/4	1.49	.44	5
37520	6.5mm	1/4	1.75	none	5
37660	6.5mm TE*	1/4	3.62	none	5
66430	8.0mm	5/16	1.56	.44	5
37250	8.0mm	5/16	1.49	.44	5
37510	8.0mm	5/16	1.69	.75	5
37470	8.0mm	5/16	1.75	none	5
37670	8.0mm TE*	5/16	3.62	none	5
37530	10.0mm	3/8	1.75	none	5
37680	10.0mm TE*	3/8	3.62	none	5



TYPE 493-D WELDOUT™ SPOTWELD

Part No.	Diameter MM	Approx Spotweld Size, Inches	Overall Length Inches	Flat Length Inches	Qty. per/pack
66180	8.0	5/16	2.25	none	5
66190	10.00	3/8	2.25	none	5
37671	8.0 TE*	5/16	3.62	none	5
37681	10 TE	3/8	3.62	none	5

The spur point on the **Type 492-D** is designed to cut through the weld on one panel while leaving the second panel free of holes.

The modified point on the **Type 493-D** drill is chip resistant with slightly greater penetration into the second panel.

Weldout™ Spotweld Drills Sets

Selection of the most popular sizes of spotweld drills in an attractive, rugged black steel case.

TYPE 492-D WO-6 SET

Part No.	Description of Sizes
35010	6.5mm, 8.0mm & 10.0mm single-end drills with 1.75" length 6.5mm, 8.0mm & 10.0mm twin end drills with 3.62" length

TYPE 493-D WO-4 SET

Part No.	Description of Sizes
35050	8.0mm & 10mm Single-end 8.0mm & 10mm Twin-end In Type 493-D Length

Type 493-DB

Carbide ALTiN Coated Spotweld Drills

- Designed to cut spotwelds from Boron Steel
- Use in high temperature operations and difficult to machine materials. ALTiN coating improves lubricity, eliminating lubrication requirements.
- **Recommended (900 RPM - 1,000 RPM)**



TYPE 493-DB

Part No.	Diameter MM	Approx Spotweld Size, Inches	Overall Length Inches	Flat Length Inches	Qty. per/pack
85890	8.0	5/16	2.00	NONE	1

TYPE 493-DB WITH FLAT

Part No.	Diameter MM	Approx Spotweld Size, Inches	Overall Length Inches	Flat Length Inches	Qty. per/pack
85880	8.0	5/16	1.75	.750	1

Type 493-DN

TiN Coated Weldout™ Spotweld Drills
M42 Cobalt High-Speed Steel - Heavy-Duty Spur Point

- Titanium nitride coated M42 cobalt steel spotweld drills are designed for use in high strength high alloy steel commonly used in the automobile industry.
- TiN coating doubles the tool life, gives additional lubricity and protects the cutting edges of the drill in tough removal applications.
- TiN coated drills require a slower speed (490 RPM) than standard drills (1800 RPM) when drilling difficult materials.



TYPE 493-DN TiN COATED

Part No.	Diameter MM	Approx Spotweld Size, Inches	Overall Length Inches	Flat Length Inches	Qty. per/pack
73450	8.0	5/16	2.25	none	1
73460	10.00	3/8	2.25	none	1
73470	8.0 TE*	5/16	3.62	none	1
73480	10 TE	3/8	3.62	none	1