

Positive Quick Change Tap Adapters

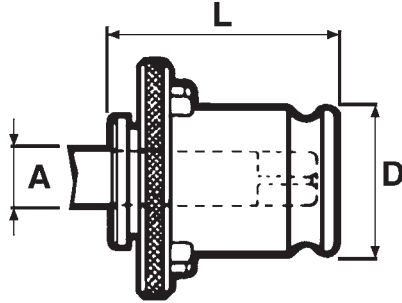

Bilz Type Tap Chucks

TAPPING PROBLEMS?

CONTACT US FOR
UNIQUE TAPPING
SOLUTIONS.

USE HIGH
PERFORMANCE
TAPS FROM



**THREADING
TECHNOLOGY**

SWISS MADE

Adapter Size	Tap Size Range	American Standard TAPS				ISO Standard Metric TAPS				DIN Standard Metric TAPS					
		order no.	tap size	A shank dia	square AF	order no.	tap size	A shank dia	square AF	order no.	tap size	A shank dia	square AF		
CE-1*	M3-M14 0-9/16" HAND D = 19mm/0.748" L = 28.5mm/1.122"	700-100	0-6	.141	.110	710-002	M1/2	2.50	2.00	710-101	M2	2.80	2.10		
		700-101	8	.168	.131	710-003	M3	3.15	2.50	710-102	M3/5	3.50	2.70		
		700-102	10	.194	.152	710-004	M4	4.00	3.15	710-103	M3.5	4.00	3.00		
		700-103	12	.220	.165	710-005	M4.5	4.50	3.55	710-104	M4/6	4.50	3.40		
		700-104	1/4	.255	.191	710-006	M5	5.00	4.00	710-106	M5/6/8	6.00	4.90		
		700-105	5/16	.318	.238	710-008	M6	6.30	5.00	710-107	M7/10	7.00	5.50		
		700-106	3/8	.381	.286	710-009	M7	7.10	5.60	710-108	M8	8.00	6.20		
		700-107	7/16	.323	.242	710-108	M8/11	8.00	6.20	710-011	M12	9.00	7.10		
		700-108	1/2	.367	.275	710-011	M9/12	9.00	7.10	710-012	M10	10.00	8.00		
		700-109	9/16	.429	.322	710-012	M10	10.00	8.00	710-111	M14	11.00	9.00		
		1/8" PIPE	700-150	1/8pss	.3125	.234	710-013	M14	11.20	9.00					
			700-151	1/8pls	.4375	.328									
		CE-2*	M7-M24 5/16-7/8" HAND D = 31mm/1.220" L = 46mm/1.811"	700-205	5/16	.318	.238	720-009	M7	7.10	5.60	720-107	M7/10	7.00	5.50
				700-206	3/8	.381	.286	720-108	M8/11	8.00	6.20	720-108	M8	8.00	6.20
				700-207	7/16	.323	.242	720-011	M9/12	9.00	7.00	720-011	M12	9.00	7.00
700-208	1/2			.367	.275	720-012	M10	10.00	8.00	720-012	M10	10.00	8.00		
700-209	9/16			.429	.322	720-013	M14	11.20	9.00	720-111	M14	11.00	9.00		
700-210	5/8			.480	.360	720-014	M16	12.50	10.00	720-112	M16	12.00	9.00		
700-211	11/16			.542	.406	720-015	M18/20	14.00	11.20	720-113	M18	14.00	11.00		
700-212	3/4			.590	.442	720-016	M22	16.00	12.50	720-114	M20	16.00	12.00		
700-213	13/16			.652	.489	720-017	M24	18.00	14.00	720-115	M22/24	18.00	14.50		
700-214	7/8			.697	.523										
1/4"-3/8" PIPE	700-250			1/4p	.562	.421									
	700-251			3/8p	.700	.531									
	700-252			1/2p	.6875	.515									
CE-3*	M14-M40 13/16-1-3/8" HAND D = 48mm/1.890" L = 69.5mm/2.736"			700-313	13/16	.652	.489	730-013	M14	11.20	9.00	730-111	M14	11.00	9.00
				700-314	7/8	.697	.523	730-014	M16	12.50	10.00	730-112	M16	12.00	9.00
		700-315	15/16	.760	.570	730-015	M18/20	14.00	11.00	730-015	M18	14.00	11.00		
		700-316	1	.800	.600	730-016	M22	16.00	12.50	730-114	M20	16.00	12.00		
		700-318	1-1/8	.896	.672	730-017	M24	18.00	14.00	730-115	M22/24	18.00	14.50		
		700-320	1-1/4	1.021	.766	730-018	M27/30	20.00	16.00	730-018	M27	20.00	16.00		
		700-322	1-3/8	1.108	.831	730-019	M33	22.40	18.00	730-117	M30	22.00	18.00		
		700-349	1/2p	.6875	.515	730-020	M36	25.00	20.00	730-020	M33	25.00	20.00		
		700-350	3/4p	.906	.679	730-021	M39/40	28.00	22.00	730-021	M36	28.00	22.00		
		700-351	1p	1.125	.843										
		CE-4*	M22-M48 1" - 1-7/8" HAND D = 60mm/2.362" L = 105mm/4.134"	700-424	1-1/2	1.233	.925					740-115	M22/24	18.00	14.50
				700-426	1-5/8	1.305	.979					740-018	M27	20.00	16.00
700-428	1-3/4			1.430	1.072					740-117	M30	22.00	18.00		
700-430	1-7/8			1.519	1.139					740-120	M33	25.00	20.00		
										740-021	M36	28.00	22.00		
										740-020	M39/42	32.00	24.00		
										740-121	M45/48	36.00	29.00		
3/4", 1" & 1-1/4" PIPE	700-452			1-1/4p	1.3125	.984									
	700-453	1-1/2p	1.5000	1.125											

* Interchangeable with WE □ Tap Adapters.



Adjustable Torque Control Tap Adapters

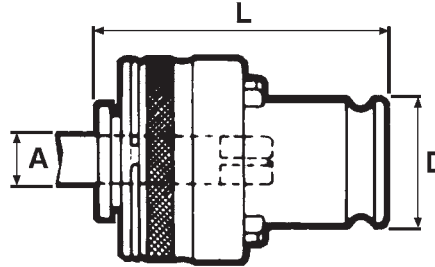

Bilz Type Tap Chucks

TAPPING PROBLEMS?

CONTACT US FOR
UNIQUE TAPPING
SOLUTIONS.

USE HIGH
PERFORMANCE
TAPS FROM



**THREADING
TECHNOLOGY**

SWISS MADE



Adapter Size	Tap Size Range	American Standard TAPS				ISO Standard Metric TAPS				DIN Standard Metric TAPS				
		order no.	tap size	A shank dia	square AF	order no.	tap size	A shank dia	square AF	order no.	tap size	A shank dia	square AF	
CES1B*	M3-M14 0-9/16" HAND D = 19mm/0.748" L = 40.5mm/1.594"	701-100	0-6	.141	.110	712-004	M4	4.00	3.15	712-101	M2	2.80	2.10	
		701-101	8	.168	.131	712-005	M4.5	4.50	3.55	712-102	M3	3.50	2.70	
		701-102	10	.194	.152	712-006	M5	5.00	4.00	712-154	M5	3.50	2.70	
		701-103	12	.220	.165	712-008	M6	6.30	5.00	712-103	M3.5	4.00	3.00	
		701-104	1/4	.255	.191	712-009	M7	7.10	5.60	712-104	M4	4.50	3.40	
		701-105	5/16	.318	.238	712-108	M8	8.00	6.20	712-155	M6	4.50	3.40	
		701-106	3/8	.381	.286	712-011	M9	9.00	7.10	712-106	M5	6.00	4.90	
		701-107	7/16	.323	.242	712-012	M10	10.00	8.00	712-156	M6	6.00	4.90	
		701-108	1/2	.367	.275	712-050	M14	8.00	6.30	712-157	M8	6.00	4.90	
		701-109	9/16	.429	.322	712-109	M12	9.00	7.00	712-107	M10	7.00	5.50	
		701-150	1/8pss	.3125	.234					712-108	M8	8.00	6.20	
		701-151	1/8pss	.4375	.328					712-109	M12	9.00	7.00	
										712-012	M10	10.00	8.00	
		CES2B*	M7-M24 5/16-7/8" HAND D = 31mm/1.220" L = 69mm/2.716"	701-205	5/16	.318	.238	722-009	M7	7.10	5.60	722-107	M7	7.00
701-206	3/8			.381	.286	722-108	M8	8.00	6.20	722-108	M8	8.00	6.20	
701-207	7/16			.323	.242	722-011	M9	9.00	7.10	722-109	M12	9.00	7.00	
701-208	12			.367	.275	722-012	M10	10.00	8.00	722-012	M10	10.00	8.00	
701-209	9/16			.429	.322	722-050	M11	8.00	6.30	722-111	M14	11.00	9.00	
701-210	5/8			.480	.360	722-109	M12	9.00	7.00	722-112	M16	12.00	9.00	
701-211	11/16			.542	.406	722-013	M14	11.20	9.00	722-113	M18	14.00	11.00	
701-212	3/4			.590	.442	722-014	M16	12.50	10.00	722-114	M20	16.00	12.00	
701-213	13/16			.652	.489	722-113	M18	14.00	11.00					
701-214	7/8			.697	.523	722-113	M20	14.00	11.00					
701-250	1/4p			.562	.421	722-016	M22	16.00	12.50					
701-251	3/8p			.700	.531	722-017	M24	18.00	14.00					
701-252	1/2p			.6875	.515									
CES3B*	M14-M40 13/16-1-3/8" HAND D = 48mm/1.890" L = 100.5mm/3.957"	701-313	13/16	.652	.489	732-013	M14	11.20	9.00	732-111	M14	11.00	9.00	
		701-314	7/8	.697	.523	732-014	M16	12.50	10.00	732-112	M16	12.00	9.00	
		701-315	15/16	.760	.570	732-015	M18	14.00	11.00	732-015	M18	14.00	11.00	
		701-316	1	.800	.600	732-015	M20	14.00	11.20	732-114	M20	16.00	12.00	
		701-318	1-1/8	.896	.672	732-016	M22	16.00	12.50	732-115	M22	18.00	14.50	
		701-320	1-1/4	1.021	.766	732-017	M24	18.00	14.00	732-158	M24	18.00	14.50	
		701-322	1-3/8	1.108	.831	732-018	M27	20.00	16.00	732-018	M27	20.00	16.00	
		701-349	1/2p	.6875	.515	732-053	M30	20.00	16.00	732-117	M30	22.00	18.00	
		701-350	3/4p	.906	.679	732-019	M33	22.40	18.00	732-118	M33	25.00	20.00	
		701-351	1p	1.125	.843	732-020	M36	25.00	20.00	732-119	M36	28.00	22.00	
CES4B*	M22-M48 1"-1-7/8" HAND D = 60mm/2.362" L = 131mm/5.157"	701-424	1-1/2	1.233	.925					742-115	M22	18.00	14.50	
		701-426	1-5/8	1.305	.979					742-158	M24	18.00	14.50	
		701-428	1-3/4	1.430	1.072					742-018	M27	20.00	16.00	
		701-430	1-7/8	1.519	1.139					742-117	M30	22.00	18.00	
										742-118	M33	25.00	20.00	
										742-119	M36	28.00	22.00	
										742-120	M39	32.00	24.00	
										742-159	M42	32.00	24.00	
1-1/4" & 1-1/2" PIPE	701-452	1-1/4p	1.3125	.984					742-121	M45	36.00	29.00		
	701-453	1-1/2p	1.500	1.125					742-160	M48	36.00	29.00		

* Interchangeable with WES □ B Tap Adapters.